

Fitting instruction **A5 2008 >**

Body
Tailgate spoiler, for scope of delivery 8T0 071 645 Edition 10.07

A5 2008 >

Contents

1	General information	1
2	Overview of components and gluing guidelines	2
2.1	Components	2
2.2	Painting guideline for primed PU-RIM components	2
2.3	Gluing guidelines	3
3	Sequence of operations	4
3.1	Preparations	4
3.2	Removing the tailgate trim	4
3.3	Mounting the tailgate spoiler	5
3.4	Re-installing the tailgate trim	8

1 General information

Please read and apply these WARNING, Caution and Note descriptions before carrying out maintenance or repair work.



WARNING!

- ◆ *Text with this symbol contains information concerning your safety and how you can reduce the risk of serious and fatal injuries.*
- ◆ *Pay special attention to the WARNING symbol. Ensure that you have read this text thoroughly.*



Caution!

- ◆ *Text with this symbol contains information on how to avoid damage to the vehicle.*
- ◆ *A Caution symbol indicates that failure to follow information can lead to vehicle damage. (e.g.: ensure that the ignition has been switched off before the battery is connected, otherwise the engine control unit can be damaged.)*



Note

- ◆ *Text with this symbol contains additional useful information.*
- ◆ *A Note symbol also contains special and additional notes on repair measures and associated information.*

Special tools are required for assembly. Improper installation can cause damage to the vehicle or the add-on components.

Audi AG shall not accept responsibility in the event of failure to comply with these assembly instructions.

2 Overview of components and gluing guidelines

2.1 Components

Components required:

Mounting kit -8T0 071 645-

Comprising:

Units	Description
1	Tailgate spoiler
1	Package of mounting hardware for tailgate spoiler ⇒ Fig. "Package contents - mounting hardware for tailgate spoiler"
1	Fitting Instructions

Package contents - mounting hardware for tailgate spoiler

- 1 - Socket head hexagon screw M6 x 14 (3x)
- 2 - Drilling template 100 x 20 (3x)
- 3 - Self-tapping screw 3.5 x 16 (1x)
- 4 - Stud bolts M6 x 30 (2x)

In addition, you will require:

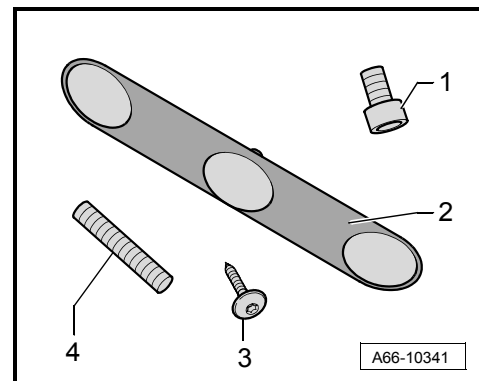

Units	Part number	Description
1	00A 071 785	Adhesive kit (Elch adhesive)

i Note

One adhesive kit is enough to install the accessory kit. The tip of the tube must be cleaned or exchanged whenever there is a pause in the gluing process. Furthermore, the processing time for the adhesive must be observed ⇒ "2.3 Gluing guidelines" on page 3 and ⇒ Information included in the adhesive kit package.

2.2 Painting guideline for primed PU-RIM components

Add-on components must always be painted in accordance with the "Audi Paintwork Guideline".

Contrary to the guideline, these add-on components must not be heated when drying - risk of deformation!

In addition, the tailgate spoiler must be supported on all 3 feet and not under any stress when being painted.

 **Caution!**

To prevent distortion, the tailgate spoiler must be supported on all 3 feet and not under any stress when being painted.

Drying the add-on components overnight at 20° C!

2.3 Gluing guidelines

- ◆ The recommended processing temperature for the Elch adhesive / 3M adhesive tape and material (vehicle & components) is between 15° C and 25° C.
- ◆ The installation process should be completed 45 minutes after opening the adhesive.
- ◆ The bonding surfaces on the body and add-on component must be absolutely dry, clean and free of wax and oil or grease.
- ◆ Clean with isopropanol immediately prior to attaching.
- ◆ Observe the information provided in the adhesive kit.

 **Caution!**

Wait at least approx. 12 hours before removing the adhesive tape.

The add-on components must not be subjected to any mechanical load for 24 hours.

Do not wash the vehicle for 48 hours.

3 Sequence of operations

3.1 Preparations

 **Note**

These add-on components are precision-manufactured and already primed. Nevertheless, they must be test-fitted in accordance with these installation instructions prior to painting. Where the holes are to be drilled may be specified only with the aid of the painted part and in accordance with these installation instructions.

- Painting the tailgate spoiler ⇒ “2.2 Painting guideline for primed PU-RIM components” on page 2.

 **Caution!**

To prevent distortion, the tailgate spoiler must be supported on all 3 feet and not under any stress when being painted.

3.2 Removing the tailgate trim

Special tools and workshop equipment required

- ♦ Pressing-off lever -80 - 200-

Removing

- Remove the warning triangle from its holder; to do so, release the catch.

- Disengage the retainer tabs with a screwdriver -arrows- and remove warning triangle holder -1-.

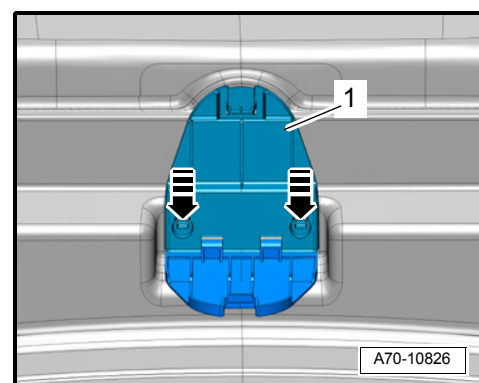
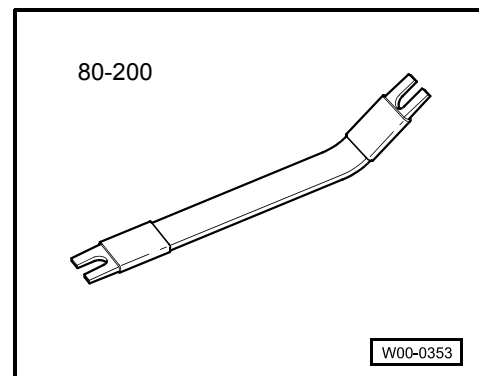

- Now pull off the trim from the tailgate lock -1- in the -di-
 rection shown by the arrow-.
- Unclip the stop strips with a screwdriver.

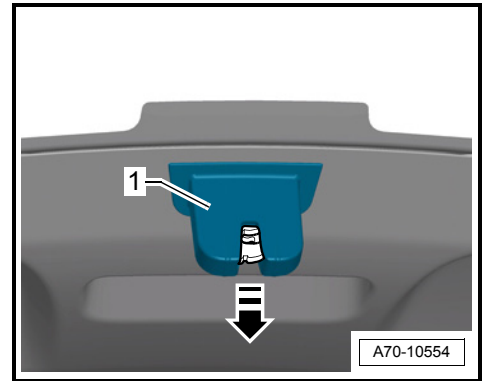

- Unscrew the screw -2- (in the recess).
- Pry off the tailgate trim -1- with the pressing-off lever -80 - 200- -arrows-.
- Unhook the tailgate trim at the hinges and remove.

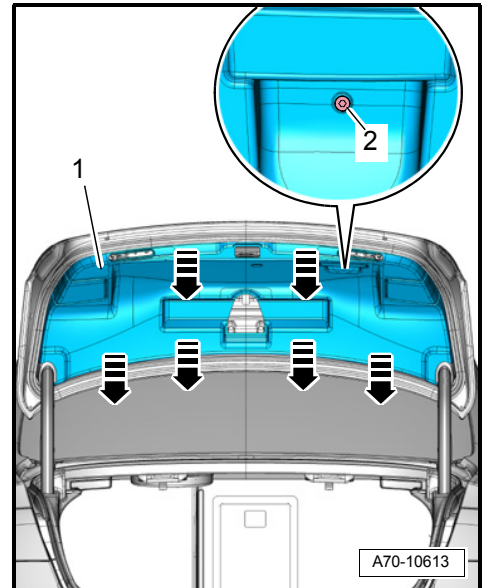

3.3 Mounting the tailgate spoiler

- To protect the interior of the luggage compartment from
 drilling chips and adhesive, line the luggage compartment
 with a protective cloth.
- Cover the mounting area for the tailgate spoiler generously
 (around all 3 feet) with adhesive tape (masking tape).
- Place the spoiler on the tailgate.

- Identify the position for the centre foot: Distance from
 front edge of tailgate to front edge of spoiler -X- =
 225 mm.
- Align side feet of spoiler with respect to sides and rear
 edge of tailgate, and outline their positions on the masking
 tape.
- Remove spoiler and check position.

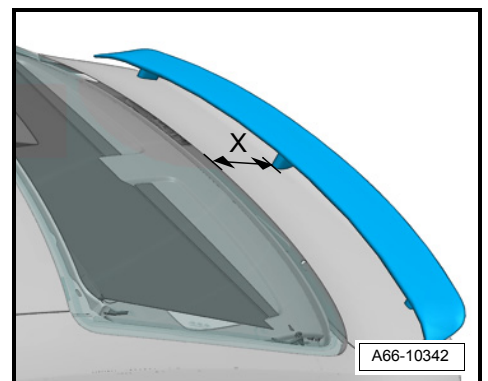

- For a tighter fit in the tailgate spoiler, expand the locating
 pins for the drilling templates provided.

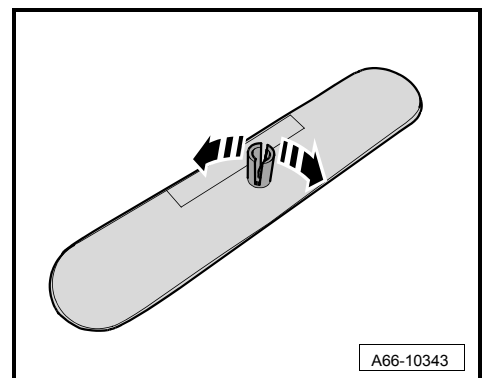

- Insert the drilling templates into the spoiler's feet and remove protective film from the outer bonding surfaces.

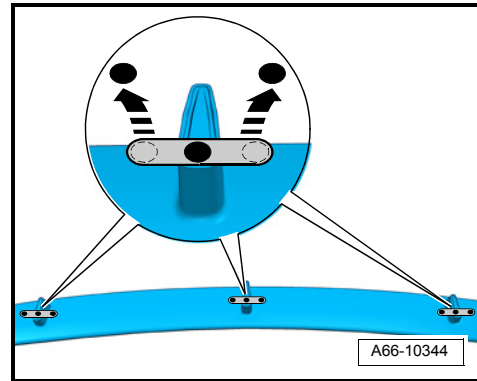

- Place the tailgate spoiler on the marked positions and apply pressure to the drilling templates.
- Remove the spoiler - the drilling templates remain on the tailgate.

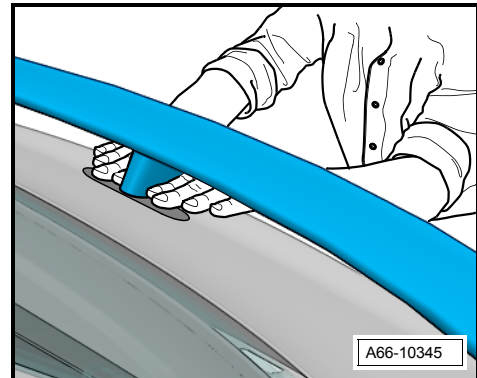

- Using a 3 mm drill bit, drill the holes in the centre of the drilling templates (3x). Drill through the reinforcing sheet metal at the centre hole.

 **Caution!**

For reasons associated with corrosion protection, use a vacuum to continually collect the drilling chips while drilling. Corrosion damage due to drilling chips is not covered by the vehicle's warranty.

- Remove the drilling templates.
- Enlarge holes to 7.0 mm.
- Measure 35 mm towards the rear from the centre hole and drill an additional \varnothing 4.0 mm hole (after drilling a 1.5 mm pilot hole).
- Open tailgate.

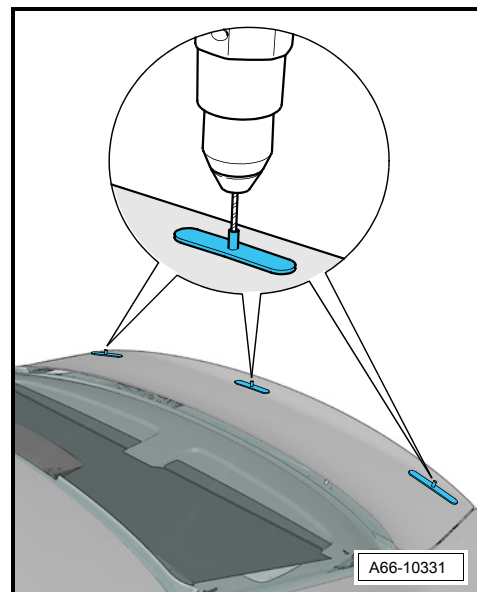

- Measure and, using a centre punch, mark holes to be drilled to provide clearance for the spoiler screws from the outside.

- a - 3 mm
- b - 12 mm

- Drill a 3 mm pilot hole first.

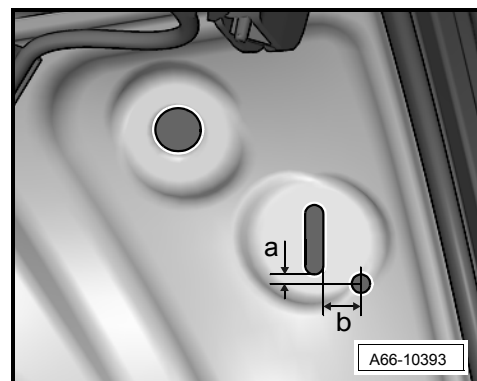

- Enlarge all holes (only in the reinforcing sheet metal inside) to 11 mm.

i Note

This space is required for the heads of the mounting screws.

- Deburr all holes.
- Remove adhesive tape (masking tape).

Measures to take to prevent corrosion

i Note

Corrosion damage due to drilling chips is not covered by the vehicle's warranty.

- Carefully remove all chips from drilling, e.g. with the help of a workshop vacuum cleaner.
- In order to provide adequate protection against corrosion, apply the following materials with a brush.
 - ◆ Single-component primer filler/surfacer -LGF 008 001 42/ A3-
 - ◆ 2-component vario filler/surfacer, grey -LGF 786 004 A3-
 - ◆ Audi paint to match the vehicle's colour
 - ◆ Body-cavity protection -D 330 KD2 A1-

Installation (cont'd)

- Roughen bonding surfaces -1-, adhesive grooves -2- and bonding surfaces on the lateral lip -3- on the tailgate spoiler; carefully remove any paint residues that may be present. Carefully roughen the bend at the front of the adhesive grooves -arrow-.

i Note

- ◆ *The highest tensile forces occur at the front in the adhesive grooves -arrow- when the car is being driven.*
- ◆ *Thorough and careful preparation of the bonding surfaces is a prerequisite for achieving a long-lasting adhesive bond.*

- Carefully clean the bonding surfaces on the tailgate and tailgate spoiler with isopropanol.
- Using a hex key, screw the M 6 threaded pins provided into the outer feet - do not tighten.

i Note

The M 6 threaded pins serve as adjustment aids when fitting the tailgate spoiler.

- Use a clean applicator tip: clean or exchange tip if necessary.

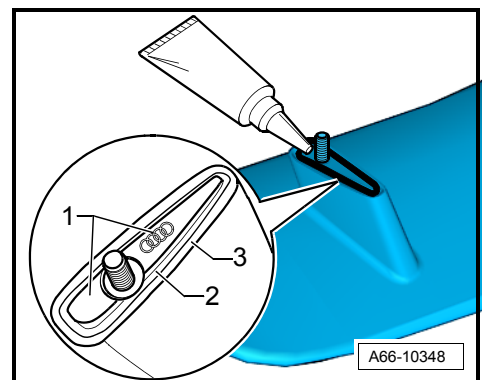
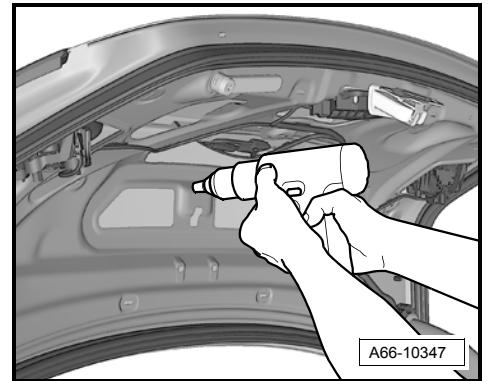

- Apply a thin film of adhesive to the entire surface -1-. Observe guidelines for the adhesive => [page 3](#).
- Apply an even bead of adhesive (approx. 4mm) Ø in the adhesive groove -2-.
- Apply an even bead of adhesive to lip -3-. The adhesive must form a unbroken sealing surface after installation.
- Set spoiler in place and guide the threaded pins in the outer feet into the holes.
- Open tailgate while holding spoiler against it by hand, and attach spoiler to tailgate at the centre using the socket head screw provided.
- Hold the spoiler in place using adhesive tape.
- Unscrew each of the outer threaded pins and screw in the socket head screws. To ensure a good seal, apply some adhesive all around the contact surface of each of the 3 socket head screws.
- Align spoiler again and secure in place from the outside using crepe tape.
- Tighten all screws.
- Screw the 3.5 x 16 self-tapping screw into the centre foot.
- Secure spoiler in place with adhesive tape until the adhesive has cured.
- Use the putty knife, cotton cloth and cleaner provided to remove any adhesive residue.
- After the adhesive used for installation has cured (on the next day), re-install the interior tailgate trim => [page 8](#).

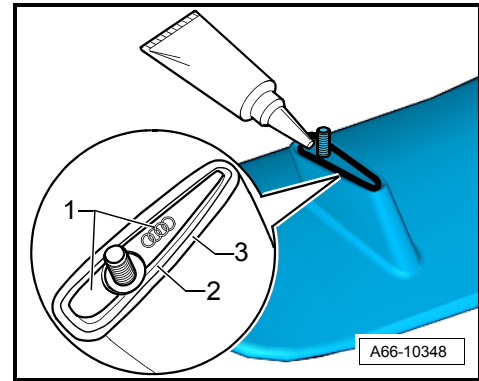

Tightening torques:

Component	Nm
M6 screw for tailgate spoiler	2
3.5 x 16 mm self-tapping screw for tailgate spoiler	2

3.4 Re-installing the tailgate trim

The trim is installed in the reverse order of removal. Please note the following points:

 **Note**

- ◆ *If fasteners for the trim remained in holes in the body used for attachment, remove the fasteners and insert into the trim for use when re-installing.*
- ◆ *Check the fasteners for damage, deformation and replace as necessary.*
- Hold tailgate trim in position and press until it snaps into place audibly.
- Press against tailgate lock trim until it snaps into place audibly.

- Press against warning triangle holder until it snaps into place audibly.

Tightening torque:

Component	Nm
Screw for tailgate trim	1,8